

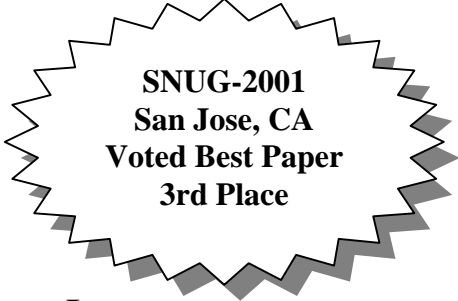

*Expert Verilog, SystemVerilog & Synthesis Training*

## **Synthesis and Scripting Techniques for Designing Multi-Asynchronous Clock Designs**

A circular award seal with a jagged, sunburst-like border. The text inside is centered and reads:

**SNUG-2001  
San Jose, CA  
Voted Best Paper  
3rd Place**

Clifford E. Cummings, Sunburst Design, Inc.

[cliffc@sunburst-design.com](mailto:cliffc@sunburst-design.com)

### **ABSTRACT**

Designing a pure, one-clock synchronous design is a luxury that few ASIC designers will ever know. Most of the ASICs that are ever designed are driven by multiple asynchronous clocks and require special data, control-signal and verification handling to insure the timely completion of a robust working design.

## 1.0 Introduction

Most college courses teach engineering students prescribed techniques for designing completely synchronous (single clock) logic. In the real ASIC design world, there are very few single clock designs. This paper will detail some of the hardware design, timing analysis, synthesis and simulation methodologies to address multi-clock designs.

This paper is not intended to provide exhaustive coverage of this topic, but is presented to share techniques learned from experience.

## 2.0 Metastability

Quoting from Dally and Poulton's book[6] concerning metastability:

"When sampling a changing data signal with a clock ... the order of the events determines the outcome. The smaller the time difference between the events, the longer it takes to determine which came first. When two events occur very close together, the decision process can take longer than the time allotted, and a synchronization failure occurs."

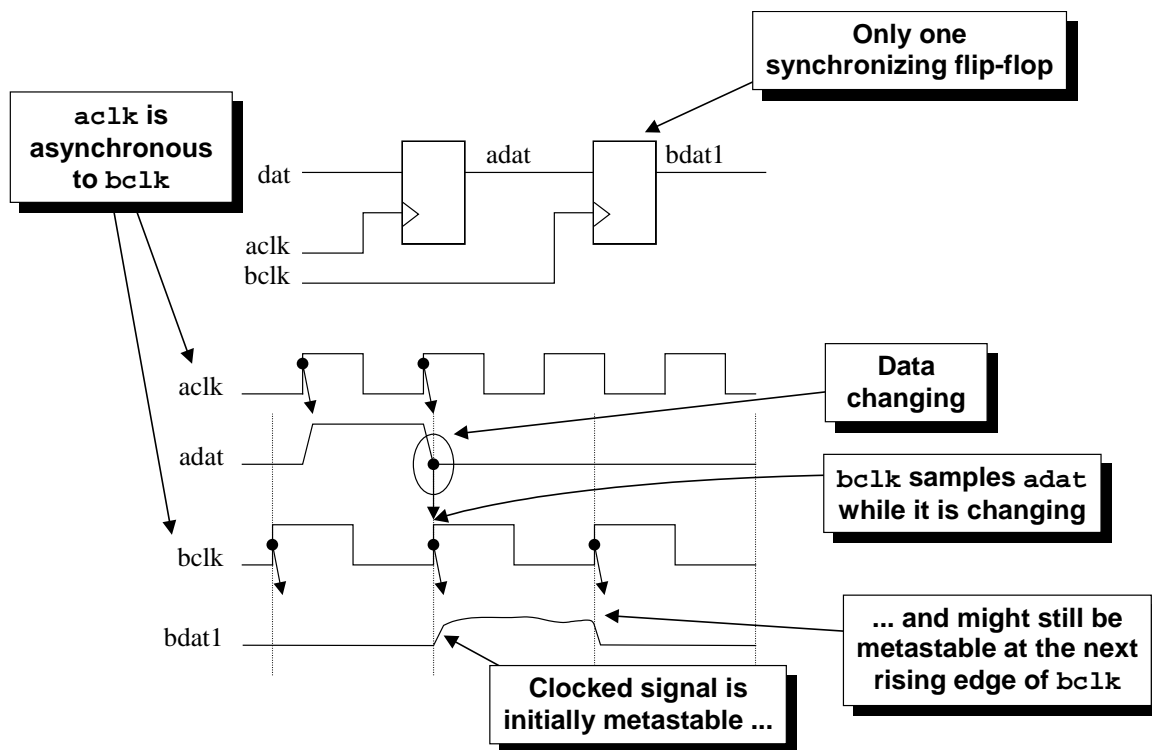

Figure 1 - Asynchronous clocks and synchronization failure

Figure 1 shows a synchronization failure that occurs when a signal generated in one clock domain is sampled too close to the rising edge of a clock signal from another clock domain.

Synchronization failure is caused by an output going metastable and not converging to a legal stable state by the time the output must be sampled again. Figure 2 shows that a metastable output can cause illegal signal values to be propagated throughout the rest of the design.

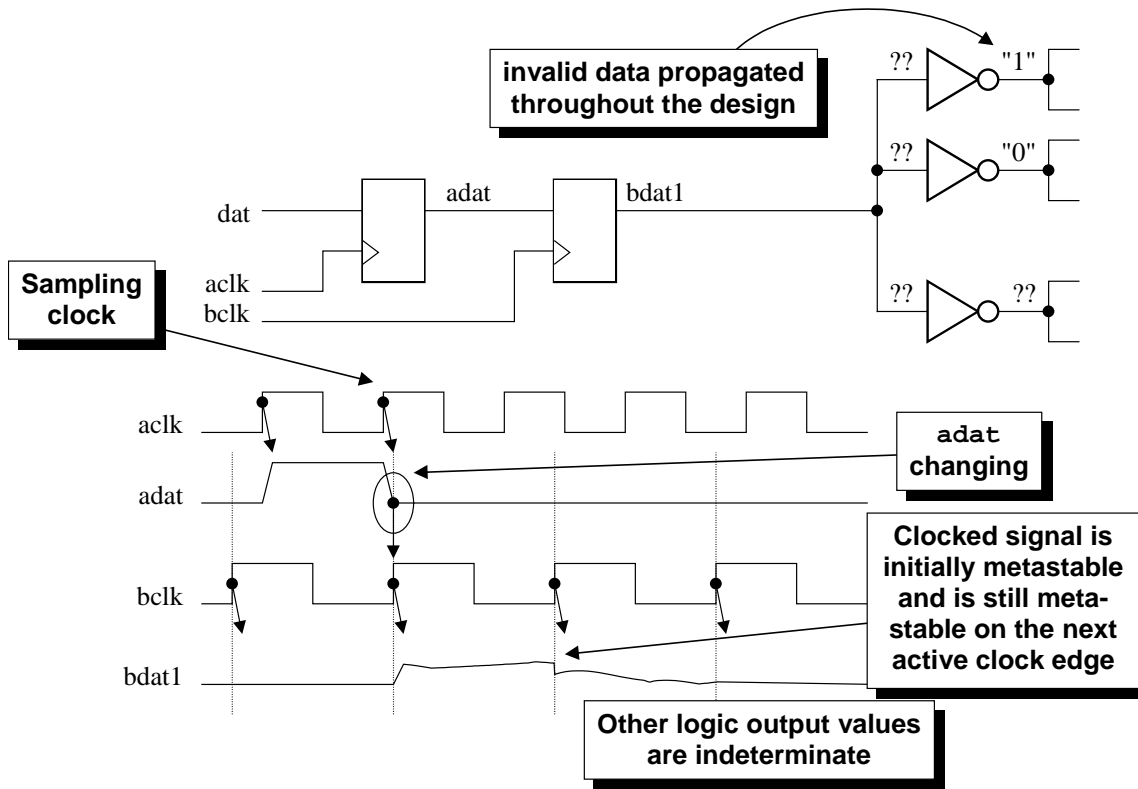

Figure 2 - Metastable bdat1 output propagating invalid data throughout the design

Every flip-flop that is used in any design has a specified setup and hold time, or the time in which the data input is not legally permitted to change before and after a rising clock edge. This time window is specified as a design parameter precisely to keep a data signal from changing too close to another synchronizing signal that could cause the output to go metastable.

The metastable output problem shown in Figure 2 is sometimes known as the John Cooley ESNUG effect, or in other words, the propagation of unwanted information!

(Just kidding, John! ☺)

### 3.0 Synchronizers

Quoting again from Dally and Poulton[7] concerning synchronizers:

"A synchronizer is a device that samples an asynchronous signal and outputs a version of the signal that has transitions synchronized to a local or sample clock."

The most common synchronizer used by digital designers is a two-flip-flop synchronizer as shown in Figure 3.

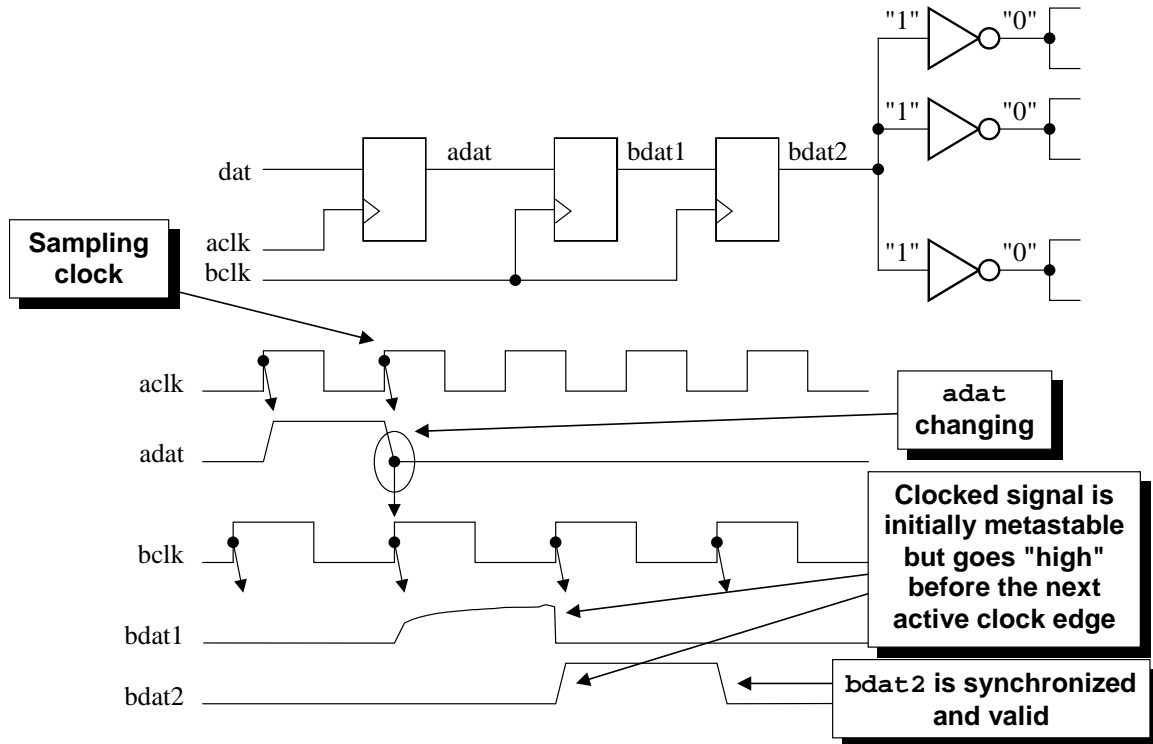

Figure 3 - Two flip-flop synchronizer

The first flip-flop samples the asynchronous input signal into the new clock domain and waits for a full clock cycle to permit any metastability on the stage-1 output signal to decay, then the stage-1 signal is sampled by the same clock into a second stage flip-flop, with the intended goal that the stage-2 signal is now a stable and valid signal synchronized into the new clock domain.

It is theoretically possible for the stage-1 signal to still be sufficiently metastable by the time the signal is clocked into the second stage to cause the stage-2 signal to also go metastable. The calculation of the probability of the time between synchronization failures (MTBF) is a function of multiple variables including the clock frequencies used to generate the input signal and to clock the synchronizing flip-flops. One description of the MTBF calculation can be found in Dally and Poulton[8].

For most synchronization applications, the two flip-flop synchronizer is sufficient to remove all likely metastability.

#### 4.0 Static Timing Analysis

Performing static timing analysis is the process of verifying that every signal path in a design meets required clock-cycle timing, whether or not all of the signal paths are even possible. Static timing analysis is not used to verify the functionality of the design, only that the design meets timing goals. In theory, timing verification could be accomplished by running exhaustive gate-level simulations with SDF backannotation of actual timing values after a design is placed and routed. This is often referred to as dynamic timing verification.

Static timing analysis has three principal advantages over dynamic timing verification: (1) static timing analysis tools verify every single path between any two sequential elements, (2) static timing analysis does not require the generation of any test vectors, and (3) static timing analysis tools are orders of magnitude faster than trying to do timing verification running exhaustive gate-level simulations[4].

Timing analysis using Synopsys tools on a completely synchronous design is relatively easy to perform using either DesignTime within the Synopsys Design Compiler or Design Analyzer environments, or by using PrimeTime.

Timing analysis on modules with two or more asynchronous clocks is error prone, more difficult and can be time consuming. Static timing analysis on signals generated from one clock domain and latched into sequential elements within a second, asynchronous clock domain is inaccurate and for the most part worthless. The timing information for a signal latched by a clock that is asynchronous to the latched signal is inaccurate because the phase relationship between the signal and the asynchronous clock is always changing; therefore, the static timing analysis tool would have to check an infinite number of phase relationships between the signal and asynchronous clock. The fact is, one must assume that signals that pass from one clock domain to another at some point will violate either setup or hold times on the destination sequential element.

There is no good reason to perform timing analysis on signals that are generated in one clock domain and registered in another asynchronous clock domain. It is a given that these signals DO violate setup and hold times on the destination register. This is why synchronizers (see section 3.0) are needed, to alleviate the problems that can occur when a signal is passed from one clock domain to another.

For RTL modules that have two or more asynchronous clocks as inputs, a designer will be required to indicate to the static timing analysis tool which signal paths should be ignored. This is accomplished by "setting false paths" on signals that cross from one clock domain to another. This can be a tedious and error prone job unless the guidelines in the next two sections are followed.

## 5.0 Clock Naming Conventions

**Guideline:** Use a clock naming convention to identify the clock source of every signal in a design.

**Reason:** A naming convention helps all team members to identify the clock domain for every signal in a design and also makes grouping of signals for timing analysis easier to do using regular expression "wild-carding" from within a synthesis script.

A number of useful clock naming conventions have been used by various design teams. One that was used by design engineers in 1995 while designing video ASICs for In Focus projectors required that a leading prefix character be used to identify the various asynchronous clock domains. Examples included: uClk for the microprocessor clock, vClk for the video clock and dClk for the display clock.

Each signal was synchronized to one of the clock domains in the design and each signal-name had to include a prefix character identifying the clock domain for that signal. Any signal that was clocked by the uClk would have a u-prefix in the signal name, such as uaddr, udata, uwrite, etc. Any signal that was clocked by the vClk would similarly have a v-prefix in the signal name, such as vdata, vhsync, vframe, etc. The same signal naming convention was used for all signals generated by any of the other clocks in the design.

Using this technique, any engineer on the ASIC design team could easily identify the clock-domain source of any signal in the design and either use the signals directly or pass the signals through a synchronizer so that they could be used within a new clock domain.

The naming convention alone contributed significantly to the productivity of the design team. How do we know there was a productivity gain? One of the design engineers started his part of the ASIC design using his own naming convention, ignoring the convention in use by the other design team members. After much confusion about the signals entering and leaving his design partition, a team meeting was called and the non-compliant designer was "strongly encouraged" to rename the signals in his part of the design to conform to the team naming convention. After the signal names were changed, it became easier to interface to the partition in question. Fewer questions and less confusions occurred after the change.

## 6.0 Design Partitioning

**Guideline:** Only allow one clock per module.

**Reason:** Static timing analysis and creating synthesis scripts is more easily accomplished on single-clock modules or groups of single-clock modules.

**Guideline:** Create a synchronizer module for each set of signals that pass from just one clock domain into another clock domain.

**Reason:** It is given that any signal passing from one clock domain to another clock domain is going to have setup and hold time problems. No worst-case (max time) timing analysis is required for synchronizer modules. Only best case (min time) timing analysis is required between first and second stage flip-flops to ensure that all hold times are met. Also, gate-level simulations can more easily be configured to ignore setup and hold time violations on the first stage of each synchronizer.

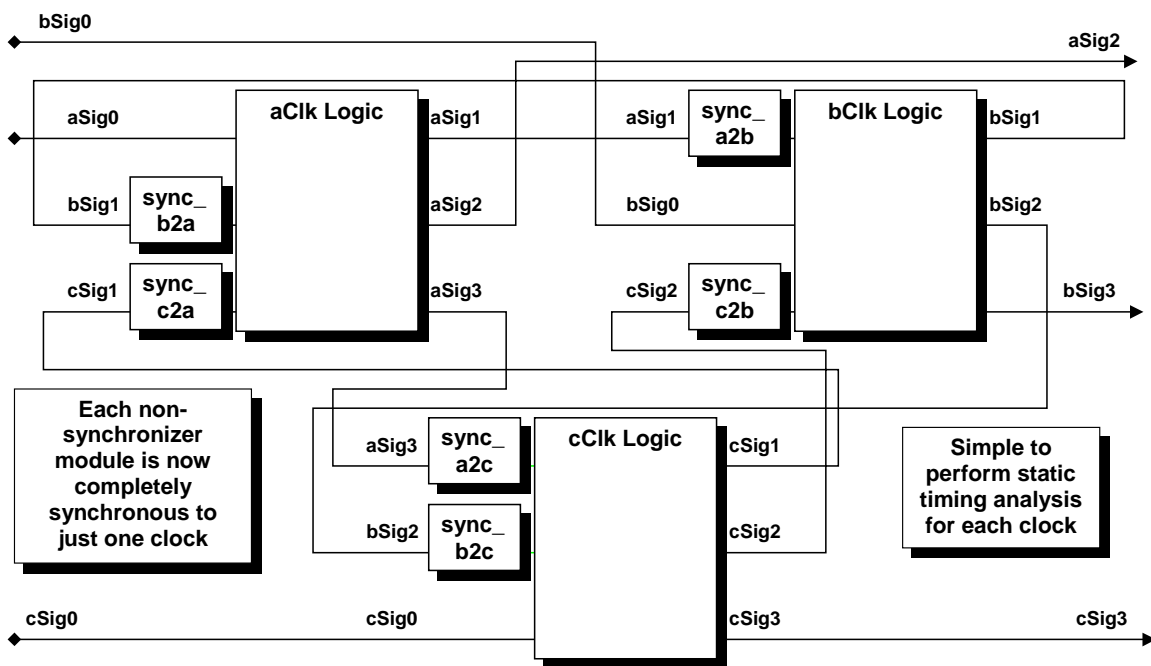

Figure 4 - Design partitioned on clock boundaries

In 1995, while working on a multi-asynchronous-clock ASIC design to be used in In Focus projectors, I received an e-mail message from Steve Golson in which he gave me the strong recommendation to only allow one clock per module for each module in the ASIC design[5]. At that time we were permitting multiple clocks per module and trying to handle timing analysis by including a large number of set\_false\_path commands in our synthesis scripts to eliminate invalid timing-error messages.

After giving consideration to Steve's recommendation, I decided to completely re-partition the ASIC design I was working on and to adhere to the recommendation to only permit one clock per module. I took a two-week hit to my schedule to re-partition the entire ASIC. After repartitioning the design, many of the timing analysis and synthesis tasks became trivial.

By partitioning a design to permit only one clock per module, static timing analysis becomes a significantly easier task.

The next logical step was to partition the design so that every input module signal was already synchronized to the same clock domain before entering the module. Why is this significant? If all signals entering and leaving the module are synchronous to the clock used in the module, the design is now completely synchronous! Now the entire module can be static timing analyzed without any "false paths" and Design Compiler can be used to "group" all of the same-clock synchronous modules to perform complete, sequential static timing analysis within each clock domain.

There is one exception to the above recommendation. Multi-clock designs require at least some RTL modules to pass signals from one clock domain to modules that are clocked within a different clock domain. For the In Focus ASIC designs, we created separate synchronizer modules that permitted signals from one and only one clock domain to be passed into a module that synchronized the signals into a new clock domain.

Using the naming convention described in section 5.0, all processor-clock generated signals (*u-signals*) would be used as inputs to a module that might be clocked by the video clock. This module was called the "sync\_u2v" module and the RTL code did nothing more than take each *u-signal* input and run it through a pair of flip-flops clocked by vClk. Aside from the vClk and reset inputs, every other input signal to the "sync\_u2v" module had a "u" prefix and every output signal from that same module had a "v" prefix.

No worst-case timing analysis is required on the "sync" modules because we know that every input signal to these modules will have timing problems; otherwise, we would not have to pass the signals through synchronizers. The only timing analysis that we need to perform within synchronizer modules is min-time (hold time) analysis between the first and second flip-flop stages for each signal.

In general, if there are  $n$  asynchronous clock domains, the design will require  $n(n-1)$  synchronizer modules, two for each pair of clock signals (example: using the uClk and vClk signals: the two synchronizer modules required would be sync\_u2v and sync\_v2u). Only if there are no signals that pass between two specific clock domains will a pair of synchronizer modules not be required.

By the way, what happened to that repartitioned In Focus ASIC design? After modifying all of the RTL files to create either completely synchronous modules or synchronizer modules, the task of generating synthesis scripts became trivial. All of the script files which previously included "set\_false\_path" commands were either deleted or significantly simplified. All timing problems were easily identified and fixed (because they were all within single-clock domain groupings) and the final synthesis runs completed two weeks earlier than anticipated, putting the project back on schedule and completely justifying the decision to repartition the design.

## 7.0 Synthesis Scripts & Timing Analysis

Following the guidelines of section 6.0, to only permit one clock per module, to require that all signals entering non-synchronizer modules are also in the same clock domain that is used to clock that module and to require that synchronizer modules only permit input signals from one other clock domain, helps to simplify the timing analysis and synthesis scripting tasks associated with a multi-clock design.

Synthesis script commands used to address multiple clock domain issues now become a matter of grouping, identifying false paths and performing min-max timing analysis.

### 7.1 Grouping

Group together all non-synchronizer modules that are clocked within each clock domain. One group should be formed for each clock domain in the design. These groups will be timing verified as if each were a separate, completely synchronous design.

### 7.2 Identifying False Paths

In general, only the inputs to the synchronizer modules require "set\_false\_path" commands. If a clock-prefix naming scheme is used (see section 5.0), then wild-cards can be used to easily identify all asynchronous inputs. For example, the sync\_u2v module should have inputs that all start with the letter "u". The following dc\_shell command should be sufficient to eliminate all asynchronous inputs from timing analysis:

```
set_false_path -from { u* }
```

### 7.3 Performing Min-Max Timing Analysis

Each grouped set of modules for each clock domain is now a completely synchronous sub-design and tools such as DesignTime or PrimeTime can be used to verify worst case timing (including setup time checks) and best case timing (including hold time checks).

The synchronizer blocks are timing verified separately. Worst case timing checks are not required because these modules are just composed of flip-flops to synchronize asynchronous input signals; therefore, there are no long path delays and the outputs are fully registered. After setting false paths on all of the asynchronous inputs, best case (minimum) timing verification is conducted to insure that hold times are met on all signals that are passed from the first to second stage synchronizing flip-flops.

## 8.0 Synchronizing Fast Signals Into Slow Clock Domains

A general problem associated with synchronizers is the problem that a signal from a sending clock domain might change values twice before it can be sampled into a slower clock domain. This problem must be considered any time signals are sent from one clock domain to another.

Synchronizing slower control signals into a faster clock domain is generally not a problem since the faster clock signal will sample the slower control signal one or more times. Recognizing that sampling slower signals into faster clock domains causes fewer potential problems than sampling faster signals into slower clock domains, a designer might want to take advantage of this fact and try to steer control signals towards faster clock domains.

### 8.1 Passing A Slow Control Signal

When passing one control signal between clock domains, a simple two-flip-flop synchronizer is typically sufficient if other rules are followed (described below).

An exception to this rule occurs when trying to pass a control signal from a faster clock domain to a slower clock domain, the control signal must be wider than the cycle time of the slower clock. If the control signal is only asserted for one fast-clock cycle, the control signal could go high and low between the rising edges of a slower clock and not be captured into the slower clock domain as shown in Figure 5 .

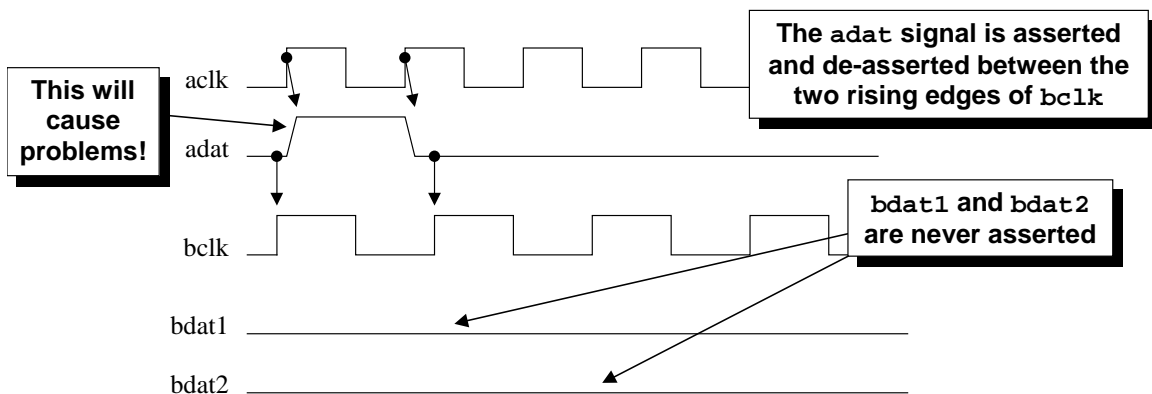

Figure 5 - Short control signal pulse missed during synchronization

One potential solution to this problem is to assert control signals for a period of time that exceeds the cycle time of the sampling clock as shown in Figure 6. The assumption is that the control signal will be sampled at least once and possibly twice by the receiver clock.



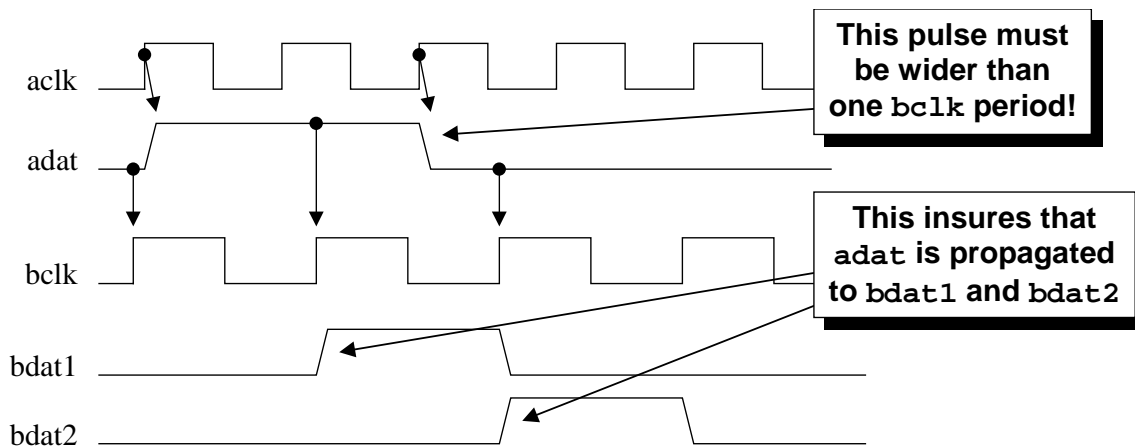

Figure 6 - Lengthened pulse to guarantee that the control signal will be sampled

A second potential solution to this problem is to assert a control signal, synchronize it into the new clock domain and then pass the synchronized signal back through another synchronizer into the sending clock domain as an acknowledge signal. Although synchronizing a feedback signal is a very safe technique to acknowledge that the first control signal was recognized and sampled into the new clock domain, there is considerable delay associated with synchronizing control signals in both directions before releasing the control signal[2].

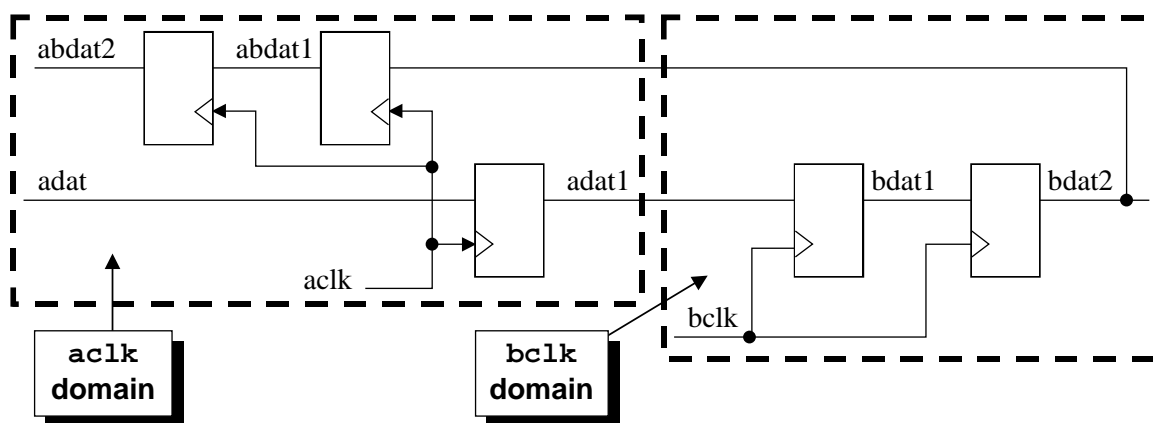

Figure 7 - Feedback synchronization of a control signal

## 9.0 Passing Multiple Control Signals

A frequent mistake made by engineers when working on multi-clock designs is passing multiple control signals from one clock domain to another and overlooking the importance of the sequencing of the control signals. Simply using synchronizers on all control signals is not always good enough as will be shown in the following examples.

If the order or alignment of the control signals is significant, care must be taken to correctly pass the signals into the new clock domain. All of the examples shown in this section are overly simplistic but they closely mimic situations that often arise in real designs.

### 9.1 Problem - Two simultaneously required control signals.

In the simple example shown in Figure 8, a register in the new clock domain requires both a load signal and an enable signal in order to load a data value into the register. If both the load and enable signals are being sent from one clock domain, there is a chance that a small skew between the control signals could cause the two signals to be

synchronized into different clock cycles within the new clock domain. In this example, this would cause the data to the register to not be loaded.

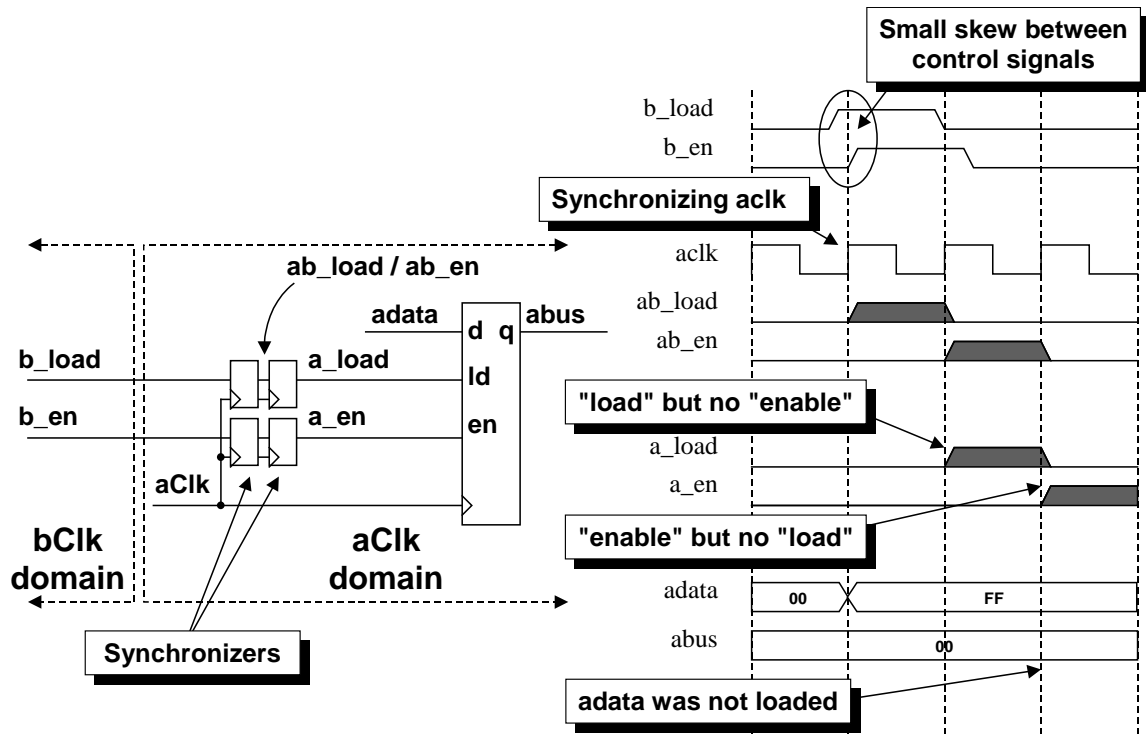

Figure 8 - Problem - Passing multiple control signals between clock domains

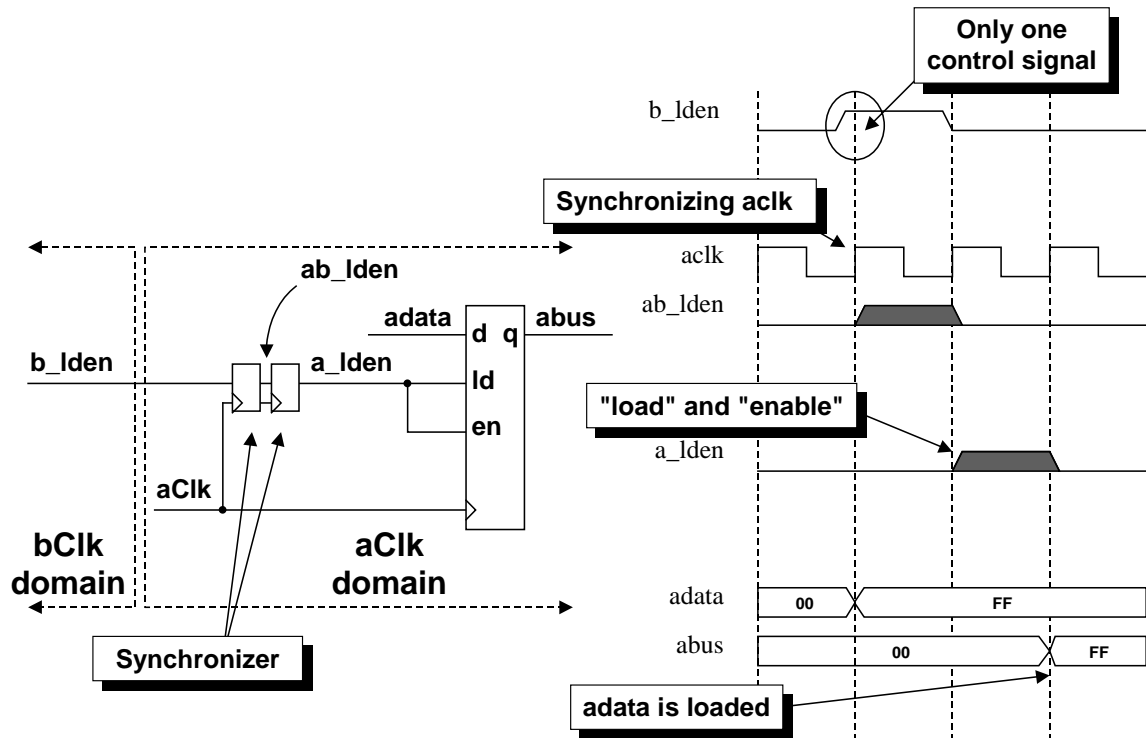

Figure 9 - Solution - Consolidating control signals before passing them between clock domains

The solution to the problem in this simple example is easy. As shown in Figure 9, drive both the load and enable register input signals in the new clock domain from just one control signal. This will remove the potential for the control signals arriving shifted in time.

## 9.2 Problem - Two phase-shifted sequencing control signals.

The diagram in Figure 10, shows two enable signals, aen1 and aen2, that are used to enable the sequential passing of a data signal through a short pipeline design. The problem is that in the first clock domain, the aen1 control signal might terminate slightly before the aen2 control signal is asserted, and the second clock domain might try to sample the aen1 and aen2 control signals in the middle of this slight time gap, causing a one-cycle gap to form in the enable control-signal chain in the second clock domain. This would cause the a2 output signal to be missed by the second flip-flop.

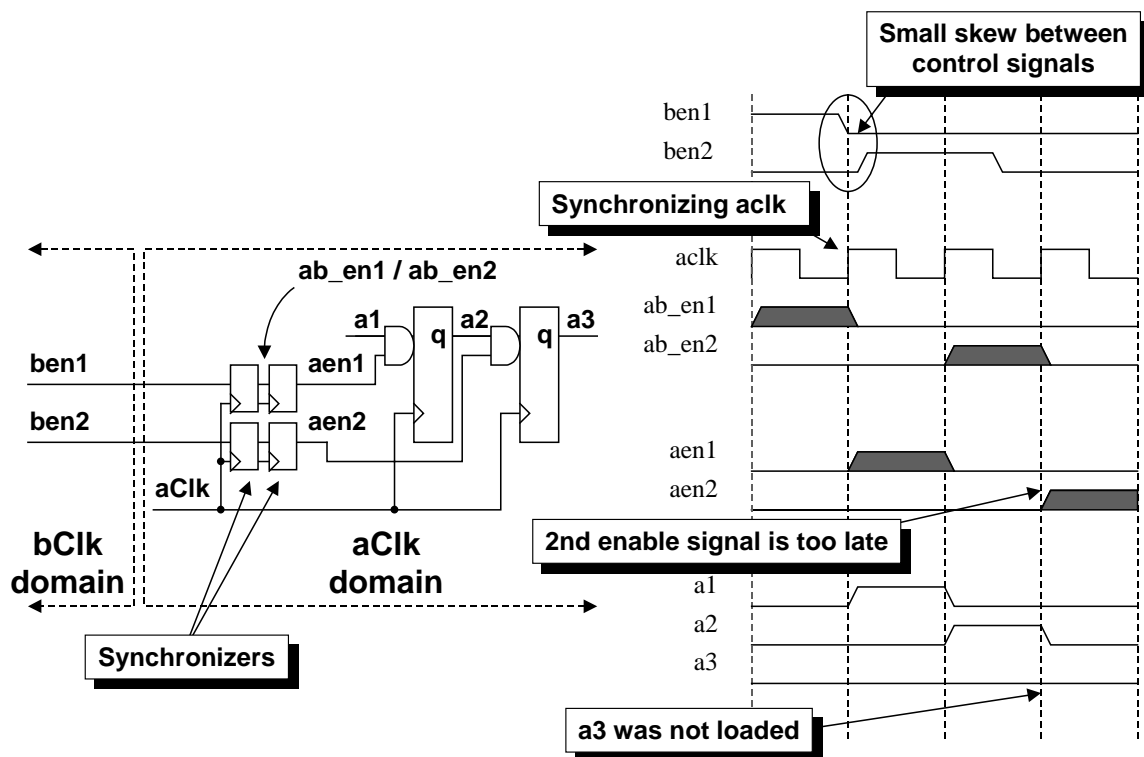

Figure 10 - Problem - Passing sequential control signals between clock domains

The solution to the problem, as shown in Figure 11, is to send only one control signal into the new clock domain and generate the second phase-shifted sequential control signal within the new clock domain.

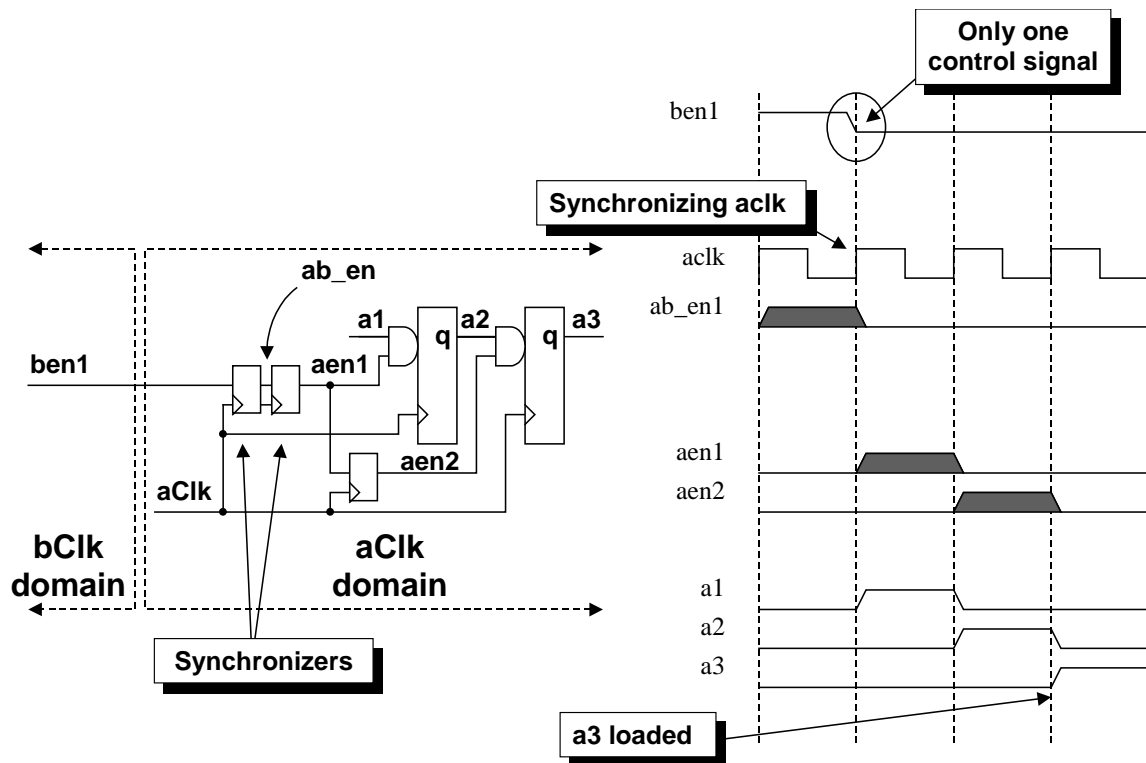

Figure 11 - Solution - Logic to generate the proper sequencing signals in the new clock domains

9.3 Problem - Two encoded control signals.

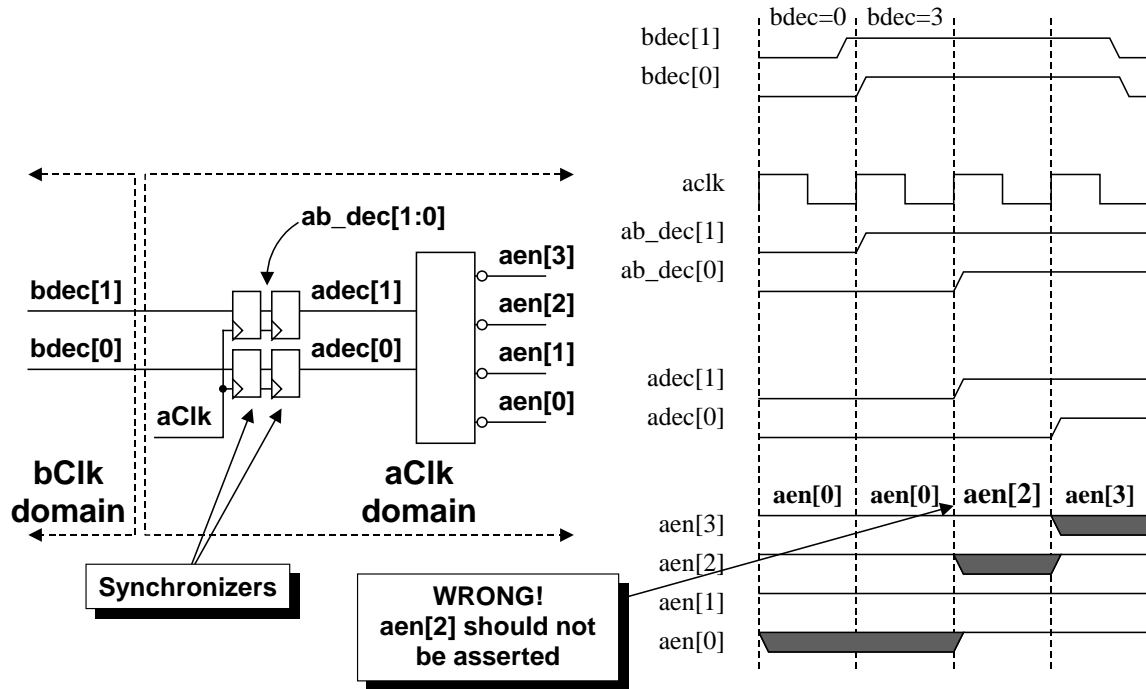

Figure 12 - Problem - Encoded control signals passed between clock domains

The diagram in Figure 12 shows two encoded control signals being passed between clock domains. If the two encoded signals are slightly skewed when sampled, an erroneous decoded output could be generated for one clock period in the new clock domain.

One potential solution to this problem, as shown in Figure 13, is to send a shaped enable signal to act as a "ready flag" in the new clock domain. The sending clock domain must generate and enable signal one clock cycle after asserting the decoder inputs. The sending clock domain must also remove the enable signal one clock cycle before de-asserting the decoder inputs. As described earlier, the enable signal must be asserted for a time period that is longer than the cycle time of the receiving clock domain.

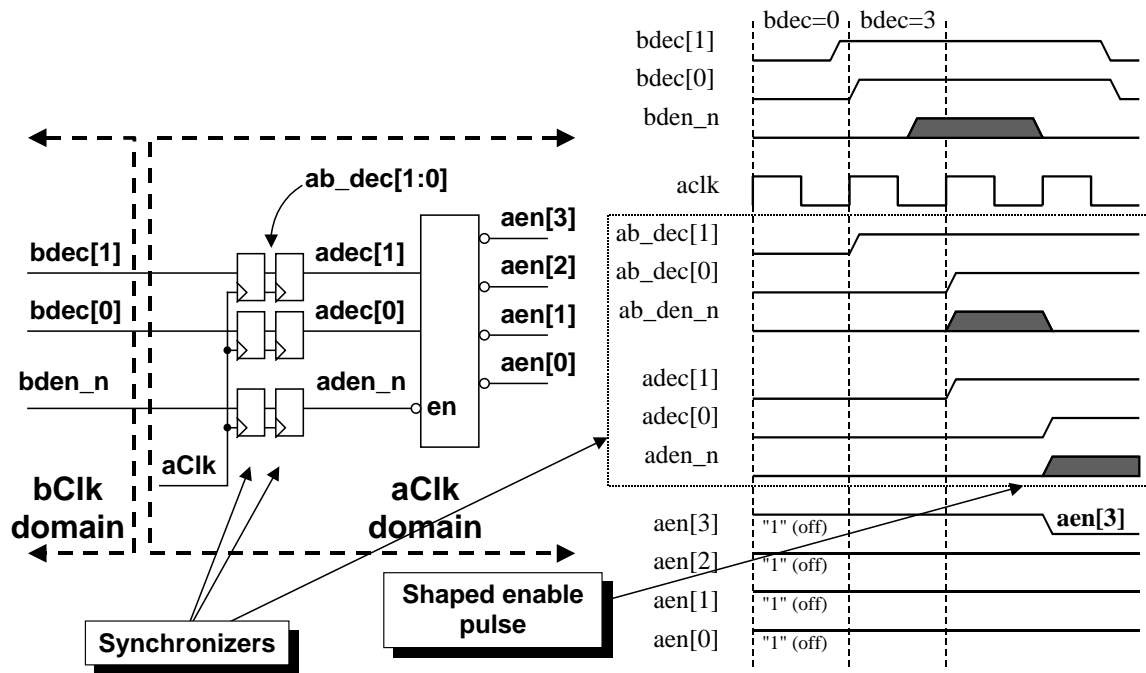

Figure 13 - Solution #1 - Logic to synchronize and wave-shape an enable pulse to pass between clock domains

Under worst case conditions, the shaped enable signal will either be sampled at the same time as the encoded inputs are sampled into the receiving clock domain, or the shaped enable signal will be de-asserted at the same time as the encoded inputs are de-asserted in the receiving clock domain. Under best case conditions, the shaped enable pulse will be asserted one receiving clock cycle later than the assertion of the encoded inputs and de-asserted one receiving clock cycle before the de-assertion of the encoded inputs. This method insures that the encoded inputs are valid before they are enabled into the receiving clock domain.

A second potential solution to this problem, as shown in Figure 14, is to decode the signals back in the sending clock domain and then send the decoded outputs (where only one of the outputs is asserted) through synchronizers into the new clock domain. Within the new clock domain, a state machine is used to determine when a new decoded output has been asserted. If there are no decoded outputs, it means that one decoded output has been de-asserted and that another decoded output is about to be asserted. If there are two asserted decoded output signals, the last decoded output signal will cause the state machine to change states and the older decoded output signal will turn off on the next rising clock edge in the new clock domain. It is important that the sender insure that the decoded outputs are each asserted for a time period that is longer than the cycle time of the receiving clock domain.

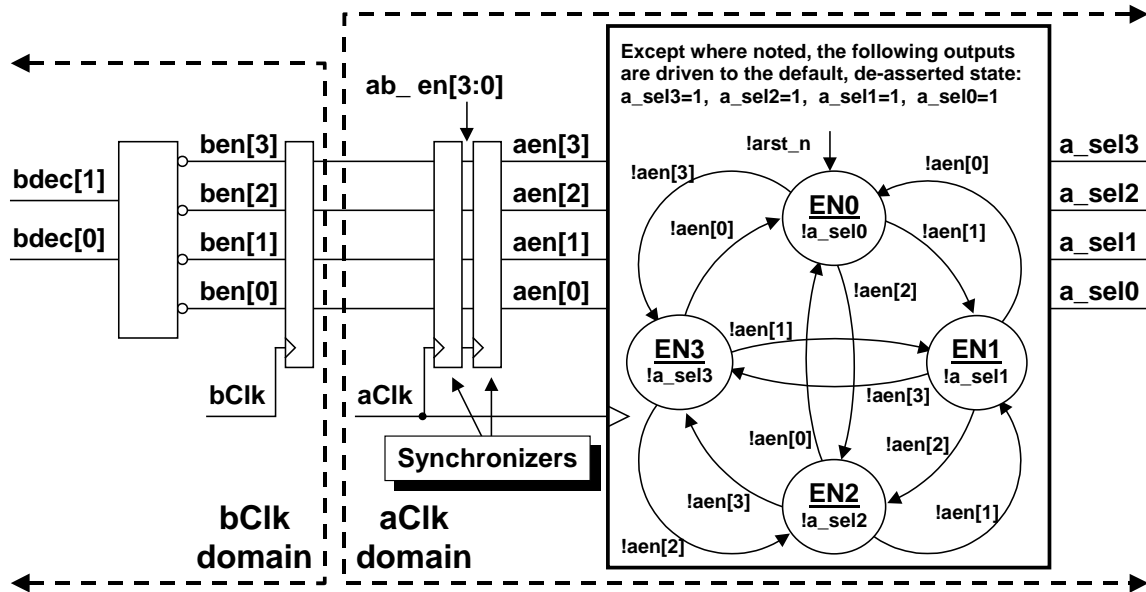

Figure 14 - Solution #2 - FSM logic to detect one-hot control signals passed from a different clock domain

Any time there are multiple control signals crossing clock boundaries, caution must be taken to insure that the sequencing of the control signals being passed is correct or that any potential mis-sequencing of the control signals will not adversely impact the correct operation of the design.

## 10.0 Data-Path Synchronization

Passing data from one clock domain to another is an example of passing multiple randomly changing signals between clock domains. Using synchronizers to handle the passing of data is generally unacceptable. There are far too many opportunities for multi-bit data changes to be incorrectly sampled using synchronizers.

Two common methods for synchronizing data between clock domains are: (1) use handshake signals to pass data between clock domains or, (2) use FIFOs (First In First Out memories) to store data using one clock domain and to retrieve data using another clock domain.

### 10.1 Handshaking Data Between Clock Domains

Data can be passed between clock domains using two or three handshake control signals, depending on the application and the paranoia of the design engineer. When it comes to handshaking, the more control signals that are used, the longer the latency to pass data from one clock domain to another. The biggest disadvantage to using handshaking is the latency required to pass and recognize all of the handshaking signals for each data word that is transferred.

For many open-ended data-passing applications, a simple two-line handshaking sequence is sufficient. The sender places data onto a data bus and then synchronizes a "data\_valid" signal to the receiving clock domain. When the "data\_valid" signal is recognized in the new clock domain, the receiver clocks the data into a register in the new clock domain (the data should have been stable for at least two rising clock edges in the sending clock domain) and then passes an "acknowledge" signal through a synchronizer to the sender. When the sender recognizes the synchronized "acknowledge" signal, the sender can change the value being driven onto the data bus.

Under some circumstances, it might be useful to use a third control signal, "ready", sent through a synchronizer from the receiver to the sender to indicate that the receiver is indeed "ready" to receive data. The "ready" signal should not be asserted while the "data\_valid" signal is true. When the "data\_valid" signal is de-asserted, a "ready" signal can be passed to the sender. Of course, with the added handshake signal comes the penalty of longer latency to synchronize and recognize the third control signal.

## 10.2 Passing Data By FIFO Between Clock Domains

One of the most popular methods of passing data between clock domains is to use a FIFO. A dual port memory is used for the FIFO storage. One port is controlled by the sender which puts data into the memory as fast as one data word (or one data bit for serial applications) per write clock. The other port is controlled by the receiver, which pulls data out of memory one data word per read clock. Two control signals are used to indicate if the FIFO is empty, full or partially full. Two additional control signals are frequently used to indicate if the FIFO is almost full or almost empty.

In theory, placing data into a shared memory with one clock and removing the data from the shared memory with another clock seems like an easy and ideal solution to passing data between clock domains. For the most part it is, but generating accurate full and empty flags can be challenging.

## 10.3 FIFO Full & Empty

Determining that a FIFO is full or empty requires some type of mathematical manipulation and/or comparison of write and read pointers. The problem is that the two pointers are generated in two different clock domains, so one or both pointers must be synchronized into the opposite clock domain before mathematical and comparison operations can be safely performed.

## 10.4 FIFO Pointers - Implemented as Binary Counters

Any FIFO pointer that must be synchronized into a different clock domain should not be implemented as a binary counter.

One characteristic of binary counters is that half of all sequential binary incrementing operations require that two or more counter bits must change. Trying to synchronize a binary counter into a new clock domain is more problematic than trying to synchronize multiple control signals into a new clock domain. If a simple 4-bit binary counter changes from address 7 (binary 0111) to address 8 (binary 1000), all four counter bits will change at the same time. If a synchronizing clock edge comes in the middle of this transition, it is possible that any 4-bit binary pattern could be sampled and synchronized into the new clock domain as shown in Figure 15.

Binary Count Values	07 -> 08 possible binary transitions
	0 1 1 1 -> 1 0 0 0 (07->08)
00 0 0 0 0	0 1 1 1 -> 0 0 0 0 (07->00)
01 0 0 0 1	0 1 1 1 -> 0 0 0 1 (07->01)
02 0 0 1 0	0 1 1 1 -> 0 0 1 0 (07->02)
03 0 0 1 1	0 1 1 1 -> 0 0 1 1 (07->03)
04 0 1 0 0	0 1 1 1 -> 0 1 0 0 (07->04)
05 0 1 0 1	0 1 1 1 -> 0 1 0 1 (07->05)
06 0 1 1 0	0 1 1 1 -> 0 1 1 0 (07->06)
07 0 1 1 1	0 1 1 1 -> 0 1 1 1 (07->07)
08 1 0 0 0	0 1 1 1 -> 1 0 0 0 (07->08)
09 1 0 0 1	0 1 1 1 -> 1 0 0 1 (07->09)
10 1 0 1 0	0 1 1 1 -> 1 0 1 0 (07->10)
11 1 0 1 1	0 1 1 1 -> 1 0 1 1 (07->11)
12 1 1 0 0	0 1 1 1 -> 1 1 0 0 (07->12)
13 1 1 0 1	0 1 1 1 -> 1 1 0 1 (07->13)
14 1 1 1 0	0 1 1 1 -> 1 1 1 0 (07->14)
15 1 1 1 1	0 1 1 1 -> 1 1 1 1 (07->15)

Figure 15 - Binary count values sampled in mid-transition

The new, synchronized binary value might trigger a false full or empty flag, or even worse, it might *not* trigger a *real* full or empty flag causing data to be lost due to FIFO overflow or causing bogus data to be read from the FIFO due to attempting to read data when the FIFO is really empty.

## 10.5 FIFO Pointers - Implemented as Gray-Code Counters

Although binary counters work fine for addressing the memory, trying to synchronize binary counters into a new clock domain is problematic. A better approach for passing pointers between clock domains is to use a gray-code counter for the two FIFO pointers. Gray code counters only change one bit at a time. If a synchronizing clock signal comes in the middle of a gray code counter transition, the synchronized value will either be the old value or the new value because only one bit is changing at a time.

## 10.6 Designing Gray Code Counters

A block diagram for a gray-code counter is shown in Figure 16. To design a gray code counter, a register is used to store the gray code values. The register output is fed back to a gray-to-binary converter, the binary value is incremented by one, the incremented binary value is then passed to a binary-to-gray converter that drives the inputs to the gray-code register.

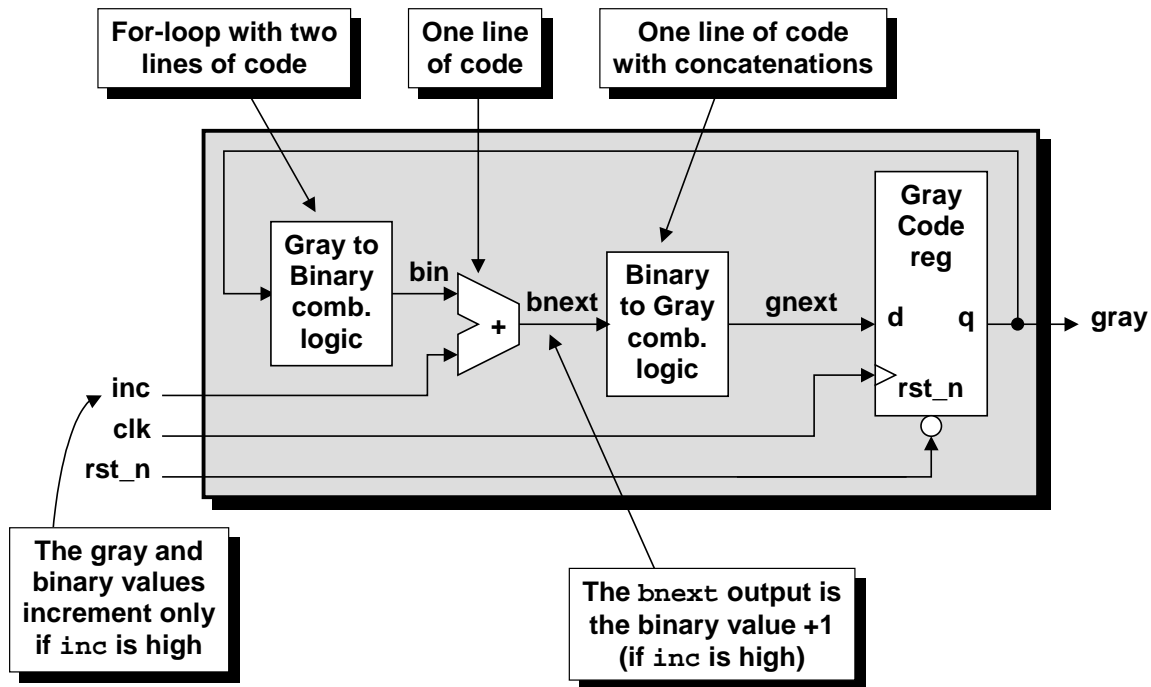

Figure 16 - Gray-code counter block diagram

## 10.7 Gray To Binary Conversion

To convert a gray-code value to an equivalent binary-code value, using an n-bit gray code value as an example, binary bit 0 is equal to the exclusive-or of gray code bit 0 exclusive-ored with all other gray code bits from 1 to n. Binary bit 1 is equal gray code bit 1 exclusive-ored with all other gray code bits from 2 to n, etc. The most significant binary bit is just equal to the most significant gray code bit. The equations for a 4-bit gray-to-binary conversion are shown in Figure 17.

```

bin[0] = gray[3] ^ gray[2] ^ gray[1] ^ gray[0];
bin[1] = gray[3] ^ gray[2] ^ gray[1];
bin[2] = gray[3] ^ gray[2];
bin[3] = gray[3];

```

Figure 17 - 4-bit gray-to-binary conversion equations



The easiest way to code a gray-to-binary converter is to code a for-loop and do an exclusive-or reduction on a gray code vector with variable index range, where each time through the loop the LSB of the index range increases until we are left with a simple assignment of  $\text{bin}[\text{MSB}] = \text{gray}[\text{MSB}:\text{MSB}]$  (just the 1-bit MSB of the gray code vector), as shown in Example 1.

```

module gray2bin_bad (bin, gray);
  parameter SIZE = 4;
  output [SIZE-1:0] bin;
  input  [SIZE-1:0] gray;
  reg    [SIZE-1:0] bin;
  integer          i;

  // Syntax Error - variable index range
  always @(gray)
    for (i=0; i<SIZE; i=i+1)
      bin[i] = ^(gray[SIZE-1:i]);
endmodule

```

Example 1 - Non-working but conceptually correct gray-to-binary Verilog model

Unfortunately, Verilog does not permit part selects using a variable index range so the code in Example 1, although conceptually correct, will not compile.

Another way to think of a gray-to-binary conversion is to exclusive-or the significant gray-code bits with padded 0's as shown in Figure 18.

```

bin[0] = gray[3] ^ gray[2] ^ gray[1] ^ gray[0] ; // gray>>0
bin[1] =  1'b0  ^ gray[3] ^ gray[2] ^ gray[1] ; // gray>>1
bin[2] =  1'b0  ^  1'b0  ^ gray[3] ^ gray[2] ; // gray>>2
bin[3] =  1'b0  ^  1'b0  ^  1'b0  ^ gray[3] ; // gray>>3

```

Figure 18 - 4-bit gray-to-binary conversion equations - 2nd method

The corresponding parameterized Verilog model for this algorithm is shown in Example 2. This example is syntactically correct, will compile and does work.

```

module gray2bin (bin, gray);
  parameter SIZE = 4;
  output [SIZE-1:0] bin;
  input  [SIZE-1:0] gray;
  reg    [SIZE-1:0] bin;
  integer          i;

  always @(gray)
    for (i=0; i<SIZE; i=i+1)
      bin[i] = ^(gray>>i);
endmodule

```

Example 2 - Parameterized and correct gray-to-binary Verilog model

## 10.8 Binary To Gray Conversion

To convert a binary value to an equivalent gray-code value, using an n-bit binary value as an example, gray-code bit 0 is equal to the exclusive-or of binary bits 0 and 1. Gray-code bit 1 is equal to the exclusive-or of binary bits 1 and 2, etc. The most significant gray-code bit is just equal to the most significant binary bit. The equations for a 4-bit binary-to-gray conversion are shown in Figure 19.

```
gray[0] = bin[0] ^ bin[1];
gray[1] = bin[1] ^ bin[2];
gray[2] = bin[2] ^ bin[3];
gray[3] = bin[3];
```

Figure 19 - 4-bit binary-to-gray conversion equations

The easiest way to code a binary-to-gray converter is to code a simple continuous assignment that performs a bit-wise exclusive-or operation between the binary vector and a right-shifted version of the same binary vector as shown in Example 3. This example is syntactically correct, will compile and does work.

```
module bin2gray (gray, bin);
  parameter SIZE = 4;
  output [SIZE-1:0] gray;
  input  [SIZE-1:0] bin;

  assign gray = (bin>>1) ^ bin;
endmodule
```

Example 3 - Parameterized binary-to-gray Verilog model

## 10.9 Gray Code Counter

The Verilog code for a gray-code counter incorporates a gray-to-binary converter, a binary-to-gray converter and increments the binary value between conversions. The parameterized Verilog model for the gray-code counter is shown in Example 4.

```
module graycptr (gray, clk, inc, rst_n);
  parameter SIZE = 4;
  output [SIZE-1:0] gray;
  input      clk, inc, rst_n;
  reg  [SIZE-1:0] gnext, gray, bnext, bin;
  integer      i;

  always @(posedge clk or negedge rst_n)
    if (!rst_n) gray <= 0;
    else      gray <= gnext;

  always @(gray or inc) begin
    for (i=0; i<SIZE; i=i+1)
      bin[i] = ^(gray>>i);
    bnext = bin + inc;
    gnext = (bnext>>1) ^ bnext;
  end
endmodule
```

### 11.0 FIFO Design

**NOTE:** an updated FIFO design paper is available at the Sunburst Design web site[1] and is recommended over the FIFO design description that follows in this section. Readers should review the referenced paper.

When passing data between two different clock domains, FIFOs, or First-In, First-Out memories, are the design-block of choice for most engineers. Figure 20 shows a block diagram for a FIFO design.

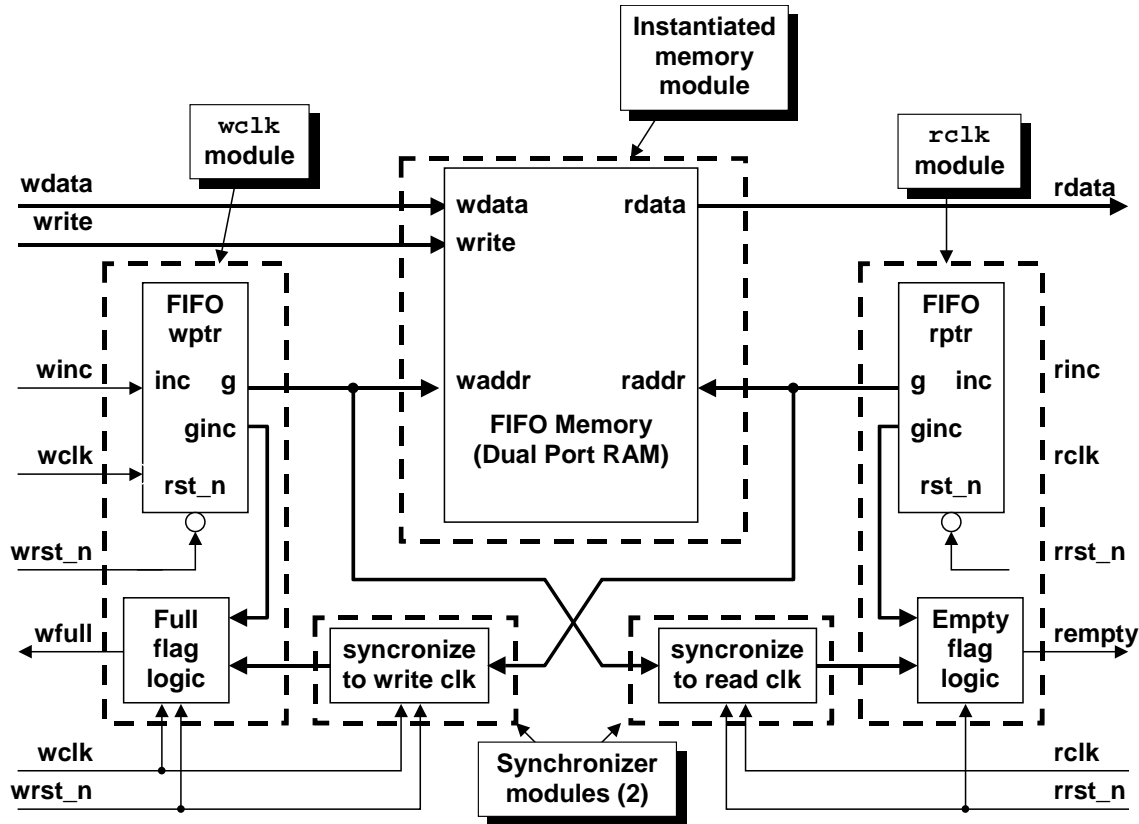

Figure 20 - FIFO Block Diagram - partitioned on clock boundaries

#### 11.1 FIFO Write and Read Operations

For the purposes of this paper, a FIFO write operation is an operation that loads a data word into the FIFO. FIFO write operations are sometimes called FIFO fill, FIFO load, etc.

For the purposes of this paper, a FIFO read operation is an operation that removes a data word from the FIFO. FIFO read operations are sometimes called FIFO drain, etc.

Since full and empty flags are generated by pointers where at least one of the pointers must be synchronized into a second clock domain, clock-cycle accurate assertion and de-assertion of full and empty flags is not completely possible.

One FIFO design technique is to insure that a full or empty flag is asserted exactly when full or empty conditions occur, but de-asserting the flags might come a few clock cycles late. This is sometimes referred to as pessimistic full and empty flags.

## 11.2 Pessimistic full and empty flags

A pessimistic full flag is a full signal that is asserted immediately when a FIFO becomes full but is de-asserted late (it is not de-asserted until a few read-clock cycles later).

Because the write pointer does not have to be synchronized before testing for a full condition, the full flag will be asserted immediately when the FIFO goes full. The FIFO might not actually be completely full because the read pointer might have incremented but the new read pointer value might not have been synchronized into the write clock domain. Using the block diagram shown in Figure 20, the read pointer synchronized into the write clock domain is always two write clocks behind the actual read pointer value, so the full flag might be asserted for two extra write clocks. This typically is not a problem since the full flag is simply holding off transmission of more data from the data sending source for two extra write clock cycles. Pointers being synchronized into a new clock domain should be gray code counters for reasons explained in sections 10.4 and section 10.5.

Similarly, because the read pointer does not have to be synchronized before testing for an empty condition, the empty flag will be asserted immediately when the FIFO goes empty. The FIFO might not actually be completely empty because the write pointer might have incremented but the new write pointer value might not have been synchronized into the read clock domain. Using the block diagram shown in Figure 20, the write pointer synchronized into the read clock domain is always two read clocks behind the actual write pointer value, so the empty flag might be asserted for two extra read clocks. This typically is not a problem since the empty flag is merely informing the data receiver that data is not ready to be sent for another two read clock cycles. Again, pointers being synchronized into a new clock domain should be gray code counters for reasons explained in sections 10.4 and section 10.5.

## 11.3 Full & Empty

A FIFO is full when both pointers are equal. A FIFO is also empty when both pointers are equal, so the FIFO pointers should be one bit larger than is necessary to address the full memory range. The extra bit is used as a flag to help determine if the FIFO is empty or full. If the extra, pointer MSBs are equal, it means that the FIFO pointers have wrapped back to address 0 an equal number of times and if the rest of the FIFO bits are equal, the FIFO is empty. If the extra, pointer MSBs are not equal, it means that the write pointer has wrapped back to address 0 one more time than the read pointer and if the rest of the FIFO bits are equal, the FIFO is full.

## 12.0 Simulation Issues

As mentioned in section 4.0, signals crossing clock boundaries through a synchronizer will experience setup and hold violations. That is why synchronizers are added to a design, to filter out the metastability effects of a signal that changes too close to the rising edge of a new clock domain clock signal.

When doing gate-level simulations on a multi-clock design, the ASIC library models of flip-flops are modeled with setup and hold time expressions to match the timing specifications of the actual flip-flops. ASIC libraries typically model flip-flops to drive X's (unknowns) on the flip-flop outputs when a timing violation occurs. When simulating gate-level synchronizers, setup and hold time violations might cause ASIC libraries to issue setup and hold time error messages and the offending signals are frequently driven to an X value. These X-values propagate to the rest of the design causing problems when trying to verify the functionality of the entire gate-level design.

Most Verilog simulators have a command option to ignore all timing checks, but this would also ignore the desired timing checks for the rest of the design.

It is possible to change the setup and hold time setting to zero for any ASIC library flip-flop that is used in a synchronizer, but that would cause all setup and hold time checks of all instances of that same type of flip-flop to be set to zero, including the flip-flops that you might want to use to test the rest of the design.

You could make copies of flip-flops from an ASIC library and store them into a new Verilog library with different names, set to zero all setup and hold times, then modify the design gate-level netlist, replacing all first stage synchronizer ASIC library flip-flops with the modified library flip-flops without timing checks, but this could be an error prone and tedious process that might have to be repeated each time a new netlist is generated or it might

require the creation of a makefile and scripts to automatically make the modifications each time a new netlist is generated.

A clever way to approach this problem suggested by Bhatnagar[3] is to use Synopsys commands to modify the SDF backannotation of the setup and hold time on just the first stage flip-flop cells in the design. Bhatnagar points out that the SDF file is instance based and therefore targeting the setup and hold times for the offending cells is more easily accomplished. Bhatnagar notes:

Instead of manually removing the setup and hold-time constructs from the SDF file, a better way is to zero out the setup and hold-times in the SDF file, only for the violating flops, i.e., replace the existing setup and hold-time numbers with zero's.

Bhatnagar further points out that setup hold times of zero means that there can be no timing violation, therefore no unknowns propagated to the rest of the design. The following dc\_shell command, given by Bhatnagar, is used to make setup and hold times zero:

```
set_annotated_check 0 -setup -hold -from REG1/CLK -to REG1/D
```

Using a creative naming convention for the output of the first stage flip-flop of a synchronizer might make wild card expressions possible to easily backannotate all first stage flip-flop SDF setup and hold time values to zero using very few dc\_shell commands.

## 13.0 Conclusions

Completely synchronous one-clock design techniques are well known. Synthesis tools do their best work on synchronous designs. Timing analysis tools are designed to report timing problems on one-clock synchronous designs. Synthesis scripts are easy to create for one-clock synchronous clock designs. The techniques in this paper are aimed at making the design look like multiple single clock designs!

- **Partitioning non-synchronizer blocks** so that there is only one clock per module permits easy verification of correct timing by creating clock-domain sub-blocks that can be more easily verified with static timing analysis tools.
- **Partitioning synchronizer blocks** to permit inputs from one and only one clock domain and clocking the signals with only one asynchronous clock creates manageable synchronizer sub-blocks that can also be easily timed.
- **A clock-oriented naming convention** can be useful to help identify signals that need to be timed within the different asynchronous clock domains.
- **Multiple control signals crossing clock domains** require special attention to ensure that all control signals are properly sequenced into a new clock domain.

The techniques described in this paper were developed to facilitate robust development and verification of multi-clock designs.

## 14.0 Errata and Changes

Readers are encouraged to send email to Cliff Cummings ( [cliffc@sunburst-design.com](mailto:cliffc@sunburst-design.com) ) any time they find potential mistakes or if they would like to suggest improvements. Cliff is always interested in other techniques that engineers are using.

### 14.1 Revision 1.2 (June 2005) - What Changed?

**Errata** - A colleague, Zenja Chao, pointed out that the equations of Figure 19 had the binary (**bin**) and gray (**gray**) labels swapped in the equations. The equations have been corrected.

## References

- [1] Clifford E. Cummings, "Simulation and Synthesis Techniques for Asynchronous FIFO Design," *SNUG 2002 (Synopsys Users Group Conference, San Jose, CA, 2002) User Papers*, March 2002, Also available at: [www.sunburst-design.com/papers](http://www.sunburst-design.com/papers)
- [2] ESNUG #281 - <http://www.deepchip.com/posts/0281.html>
- [3] Himanshu Bhatnagar, *Advanced ASIC Chip Synthesis*, Kluwer Academic Publishers, 1999, pp. 202-203.
- [4] Samir Palnitkar, *Verilog HDL, A Guide to Digital Design and Synthesis*, Sunsoft Press A Prentice Hall Title, 1996, pg. 193.
- [5] Steve Golson, personal communication.
- [6] William J. Dally and John W. Poulton, *Digital Systems Engineering*, Cambridge University Press, 1998, pg. 468.
- [7] William J. Dally and John W. Poulton, *Digital Systems Engineering*, Cambridge University Press, 1998, pp. 462-513.
- [8] William J. Dally and John W. Poulton, *Digital Systems Engineering*, Cambridge University Press, 1998, pp. 469-470.

Synopsys is a registered trademark of Synopsys, Inc.

Design Analyzer, DesignTime, PrimeTime and Synopsys Design Compiler are trademarks of Synopsys, Inc.

## Author & Contact Information

**Cliff Cummings**, President of Sunburst Design, Inc., is an independent EDA consultant and trainer with 23 years of ASIC, FPGA and system design experience and 13 years of Verilog, SystemVerilog, synthesis and methodology training experience.

Mr. Cummings, a member of the IEEE 1364 Verilog Standards Group (VSG) since 1994, is the only Verilog and SystemVerilog trainer to co-develop and co-author every IEEE 1364 Verilog Standard, the IEEE 1364.1 Verilog RTL Synthesis Standard, every Accellera SystemVerilog Standard, and the IEEE 1800 SystemVerilog Standard.

Mr. Cummings holds a BSEE from Brigham Young University and an MSEE from Oregon State University.

Sunburst Design, Inc. offers Verilog, Verilog Synthesis and SystemVerilog training courses. For more information, visit the [www.sunburst-design.com](http://www.sunburst-design.com) web site.

Email address: [cliffc@sunburst-design.com](mailto:cliffc@sunburst-design.com)

An updated version of this paper can be downloaded from the web site: [www.sunburst-design.com/papers](http://www.sunburst-design.com/papers)

(Last updated June 20<sup>th</sup>, 2005)